

ABERMAN
PROFESSIONAL AUDIO-VIDEO SOLUTIONS
aDA-2xxxT Series



2-channel Power Amplifier Series
Class D with Switching Power Supply

Table of Contents

1	Introduction	3
2	Features	3
3	Package Contents	3
4	Unit's interfaces	4
4.1	Front Panel	4
4.2	Rear Panel	5
4.3	External Connections	6
5	Best Practice	7
6	Safety Instructions	7
7	Warranty Information	7
8	Specifications	8
8.1	aDA-2120T	8
8.2	aDA-2240T	9
8.3	aDA-2350T	10
8.4	aDA-2500T	11

1. Introduction

Aberman aDA-2xxxT series are two-channel power amplifiers which offer high quality audio amplifying for professional and commercial use. This two-channel digital amplifier's family consists of four models with rated power from 120W to 500W. Each model is a Class D high efficient amplifier with low power consumption because of using switching power supply technology. Each of two channels has its universal input which is support connection of balanced and un-balanced analog sources. The separate regulation for channel level and high pass filter are provided also. The outputs could be independently used with low or high impedance load which seriously expand usability of the units. Thanks to different types of protection realized for outputs and active cooling system these models offers long and stable functionality in 24/7 mode what is extremely important for professional use cases. The standby feature adds additional benefit for power saving. Amplifiers equipped with universal power supply with wide range input voltages support from 115 to 230V. Units housed in the compact 1RU chassis and ready for the standard 19 inches rack mounting.

2. Features

- Two channel power amplifier
- Class D amplifier with efficiency up to 85%
- Switching power supply technology
- Rated power from 120W to 500W depending on model
- Low or High impedance outputs for 8Ohm and 100V speakers
- Balanced and Un-balanced input signal support
- Independent level and HPF control for the each channel
- Separate control for standby function for each channel
- Front panel indication for input signal detection, clipping, standby and output
- Short circuit, overload, high temperature, signal clipping and DC protection
- High durability phoenix connectors for inputs and outputs with screws locking
- Housed in compact chassis 1RU

3. Package Contents

1x 2-channel Power Amplifier Unit
1x AC Power Cord
1x Quick Start Guide

4. Unit's interfaces

4.1 Front Panel



The front panel of the unit is equipped with mains power switch and status indicators.

Control Element	Function
POWER	LED, Power status, active when unit turned on
PROT/STBY	LED, Protection or Standby status, active when Output is Disabled
CLIP	LED, Clipping status, active when signal in channel clipped
INPUT	LED, Input status, active when input signal is detected
OUTPUT	LED, Output status, active when signal is being sent to output
Switch	Function
POWER	turns unit on/off

Power Switch and LED

Switch unit mains on or off. Power LED lit blue when unit turned on (regardless what power source is being used – AC mains or emergency 24V power).

Protection / Standby

Orange LED lit – means that output is currently disabled by the activated Protection or Standby functions.

Protection

Switching an output to the Protection mode could be caused by several issues:

- output line short circuit detected;
- output channel overload;
- thermal sensor reports internal temperature over 55°C;
- an hardware failure.

Standby

The Standby function could be activated by the DIP-switch on the rear panel. When no input signal is detected the output will be disabled and the PROT/STBY LED will light.

Clipping

Red LED lit – means clipping is detected, this status could be caused when signal level is too high on input or output.

Input

Green LED lit – means signal present on the specified input.

Output

Green LED lit – means signal passed to the specified output.

4.2 Rear Panel



The rear panel of the unit is equipped with audio interfaces and some control functions.

Port Name	Connector type	Description
Line Input CH1,CH2	3-pin Phoenix	Connect to audio source equipment Input supports balanced or unbalanced signal sources
Speaker Output CH1,CH2	3-pin Phoenix	Connect to speaker Output supports for low or high impedance load
DC 24V IN	4-pin Phoenix	Connect to the reserve/emergency 24V DC power Input will be used automatically if mains AC fails
Power Socket	IEC C 14	Connect to the mains AC power line Internal power supply supports for ~110-230V AC
Control Element		Function
VOL/LEVEL CH1,CH2	Potentiometer	Set input sensitivity to appropriate level Turn clockwise - increase/counter-clockwise – decrease
HPF CH1,CH2	DIP Switch	High Pass Filter control Turn on/off HPF for a selected channel
STANDBY CH1,CH2	DIP Switch	Standby function control Turn on/off Standby for a selected channel

VOL/LEVEL

These regulators allow user to adjust sensitivity for the input signal level to achieve the demanding output level for each channel. Turning the potentiometer clockwise will increase sensitivity for the corresponding input, while turning counter-clockwise decreasing it. Settings are independent for the each channel.

HPF

HPF stands for High Pass Filter and allows to turn filter on or off for the corresponding channel. Selection could be done by setting the DIP-switch up or down. When filter is turned on (upper position) the frequency response range is cut to 80Hz – 20KHz, when turned off (lower position) the output range is full 20Hz – 20KHz. Settings are independent for the each channel.

STANDBY

Standby feature are commonly used for energy saving purposes, but at the same time it may help in some situations when some unwanted low-level noise is being heard when audio source is turned off or paused. Selection could be done by setting the DIP-switch up or down. When Standby is turned on (upper position) for a channel and if no input signal will be found for 30 seconds, then this channel will be automatically turned off. The orange LED on the front panel, when the input signal will return the channel will switch back on automatically. Settings are independent for the each channel.

DC 24V IN

DC 24V 4-pin connector is used for connecting amplifier to a reserve/emergency DC 24V power line source. This power input will be used automatically if mains AC fail.

4.3 External connection

Please be careful and accurate when connecting sources and speakers to the amplifier. The wrong connection may affect not only to audio quality, but may cause abnormal working mode and damage equipment. Check connection guidance and schemes below. Each channel has separate connectors for its input and output. They are used 3-pin Phoenix type with locking screws for protecting the system from accidental cable disconnections.

Connecting of input sources

Amplifier allows connecting balanced or unbalanced analog audio signal sources to its inputs. For balanced signals - connect cables wires with direct and inverted phase signal to “+” (pin 3) and “-” (pin 1) terminals and cable shield to the “S” terminal (pin 2) of the connector.

For unbalanced signals - connect cable signal wire to “+” terminal (pin 3) and cable shield to the “S” terminal (pin 2), “-” and “S” (pin 1 & 2) terminals should be shorted.

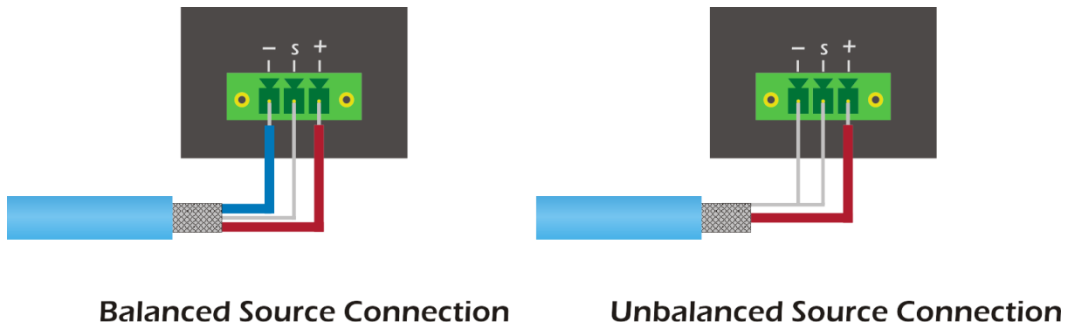

Connecting of speakers

Amplifier allows connecting for low and high impedance speakers to its outputs. For low impedance (8Ohm) speakers - connect negative wire to the “COM” terminal (pin 2) and positive wire to “8Ω” terminal (pin 3) of the connector.

For high impedance (100V) speakers - connect negative wire to the “-” terminal (pin 1) and positive wire to “+” terminal (pin 3) of the connector. When using several high impedance speakers in daisy chain - check corresponding connection for positive and negative wires on the speakers, the wrong connection will result in counter phase which will gave negative result in sound pressure and system performance. Always calculate total power of connecting speakers it should do not exceed the maximum rated power of the amplifier’s channel.

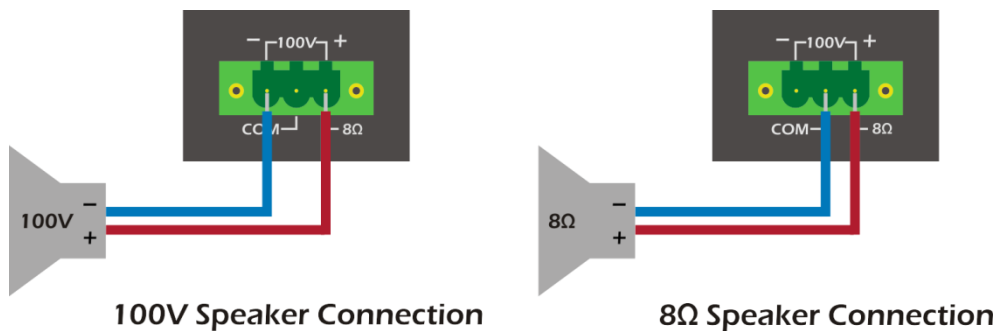

NOTE: never connect 100V and 8Ohm speakers to the one channel at the same time. Never connect low impedance speakers to high impedance output or visa-versa. Never short output terminals!

5. Best Practice

Aberman engineers design products at the highest quality standards. To get the best results and achieve maximum performance from our products, please read this manual carefully. We recommend using high quality connectors, cables, and adapters only. Consider the points below when you choose accessories and position equipment.

6. Safety Instructions

WARNING: To reduce the risk of fire or electric shock, do not expose this device to rain or moisture. Do not use this device near water. Clean only with a dry cloth.

Protect the power cord from being walked on or pinched particularly at plugs, convenience receptacles, and the point where they exit from the device. This unit must be connected to an earthed mains socket outlet with the supplied cable. The AC wall outlet should be installed near to the unit and be easily accessible.

When using extenders or cable lines which run a long distance, the protective earth circuit of the socket should be verified by a skilled person to ensure equipotential earth bonding. Do not use unit in buildings or mobile installations where power lines have grounding and/or different phase issues.

Unplug units during lightning storms or when unused for long periods of time.

Do not install unit near any heat sources such as radiators, heat registers, stoves, or devices (including amplifiers) that produce heat. Do not block any ventilation openings. This unit uses active cooling with fans. Do not install unit in dusty and/or dirty places. Use professional equipment racks with air condition and filters.

7. Warranty Information

Aberman warrants all units to be free from defects in workmanship and materials, under normal use and service, for a period of one (1) year from the date of purchasing from authorized reseller. The extended period for five (5) years could be provided for selected items.

If a product does not work as it warranted during standard period, Aberman will repair or replace the defective product or its part. Replacement products may be new or reconditioned.

Warranty ends if the product has been damaged due to abuse, misuse, neglect, accident, unusual physical or electrical stress, unauthorized modifications, tampering, alterations, or servicing other than by Aberman or its authorized centers, causes other than from ordinary use or failure to properly use the Product in the application for which said Product is intended.

8. Specifications

8.1 aDA-2120T

SKU	aDA-2120T
Type	Power Amplifier
Rated Power	2x 120W (80Ohm or 100V)
Class	D
Frequency Response	20Hz – 20KHz (+1/-2dB) (HPF off) 80Hz – 20KHz (+1/-3dB) (HPF on)
Crosstalk	<60dB (@1KHz, Max output)
Signal/Noise Ratio	>80dB
THD	<0.1% (@1KHz, -3dBu, 100W)

Interfaces

Inputs	2x Phoenix 3-pin, analog audio, mono, balanced or unbalanced
Input sensitivity	0.775V, 0dBu
Input impedance	10KOhm
Outputs	2x Phoenix 3-pin, low or high impedance

Control

Local Indication	Front Panel Power Switch with LED Status Power, Protect, Standby, Clipping, Input and Output Signal LED Status
------------------	---

Safety

Cooling	Active, 2x Ø40 fan
Protection	Short circuit, overload, high temperature, signal clipping, DC

Electrically

Power Consumption	300W (Max)
Power Supply	Internal, switching, AC 110 - 230V, 50/60Hz

Mechanical

Housing	Metal Enclosure
Color	Black
Dimensions (LxWxH)	482 x 420 x 44 mm (with rack ears), 1RU
Weight	6.5 kg

Environments

Operating Temperature	0°C ~ 40°C
Storage Temperature	-20°C ~ 70°C
Relative Humidity	10%~90% RH (non-condensing)

8.2 aDA-2240T

SKU	aDA-2240T
Type	Power Amplifier
Rated Power	2x 240W (8Ohm or 100V)
Class	D
Frequency Response	20Hz – 20KHz (+1/-2dB) (HPF off) 80Hz – 20KHz (+1/-3dB) (HPF on)
Crosstalk	<60dB (@1KHz, Max output)
Signal/Noise Ratio	>80dB
THD	<0.1% (@1KHz, -3dBu, 100W)

Interfaces

Inputs	2x Phoenix 3-pin, analog audio, mono, balanced or unbalanced
Input sensitivity	0.775V, 0dBu
Input impedance	10KOhm
Outputs	2x Phoenix 3-pin, low or high impedance

Control

Local Indication	Front Panel Power Switch with LED Status Power, Protect, Standby, Clipping, Input and Output Signal LED Status
------------------	---

Safety

Cooling	Active, 2x Ø40 fan
Protection	Short circuit, overload, high temperature, signal clipping, DC

Electrically

Power Consumption	550W (Max)
Power Supply	Internal, switching, AC 110 - 230V, 50/60Hz

Mechanical

Housing	Metal Enclosure
Color	Black
Dimensions (LxWxH)	482 x 420 x 44 mm (with rack ears), 1RU
Weight	7.5 kg

Environments

Operating Temperature	0°C ~ 40°C
Storage Temperature	-20°C ~ 70°C
Relative Humidity	10%~90% RH (non-condensing)

8.3 aDA-2350T

SKU	aDA-2350T
Type	Power Amplifier
Rated Power	2x 350W (8Ohm or 100V)
Class	D
Frequency Response	20Hz – 20KHz (+1/-2dB) (HPF off) 80Hz – 20KHz (+1/-3dB) (HPF on)
Crosstalk	<60dB (@1KHz, Max output)
Signal/Noise Ratio	>80dB
THD	<0.1% (@1KHz, -3dBu, 100W)

Interfaces

Inputs	2x Phoenix 3-pin, analog audio, mono, balanced or unbalanced
Input sensitivity	0.775V, 0dBu
Input impedance	10KOhm
Outputs	2x Phoenix 3-pin, low or high impedance

Control

Local Indication	Front Panel Power Switch with LED Status Power, Protect, Standby, Clipping, Input and Output Signal LED Status
------------------	---

Safety

Cooling	Active, 2x Ø40 fan
Protection	Short circuit, overload, high temperature, signal clipping, DC

Electrically

Power Consumption	800W (Max)
Power Supply	Internal, switching, AC 110 - 230V, 50/60Hz

Mechanical

Housing	Metal Enclosure
Color	Black
Dimensions (LxWxH)	482 x 420 x 44 mm (with rack ears), 1RU
Weight	8 kg

Environments

Operating Temperature	0°C ~ 40°C
Storage Temperature	-20°C ~ 70°C
Relative Humidity	10%~90% RH (non-condensing)

8.4 aDA-2500T

SKU	aDA-2500T
Type	Power Amplifier
Rated Power	2x 500W (8Ohm or 100V)
Class	D
Frequency Response	20Hz – 20KHz (+1/-2dB) (HPF off) 80Hz – 20KHz (+1/-3dB) (HPF on)
Crosstalk	<60dB (@1KHz, Max output)
Signal/Noise Ratio	>80dB
THD	<0.1% (@1KHz, -3dBu, 100W)

Interfaces

Inputs	2x Phoenix 3-pin, analog audio, mono, balanced or unbalanced
Input sensitivity	0.775V, 0dBu
Input impedance	10KOhm
Outputs	2x Phoenix 3-pin, low or high impedance

Control

Local Indication	Front Panel Power Switch with LED Status Power, Protect, Standby, Clipping, Input and Output Signal LED Status
------------------	---

Safety

Cooling	Active, 2x Ø40 fan
Protection	Short circuit, overload, high temperature, signal clipping, DC

Electrically

Power Consumption	1150W (Max)
Power Supply	Internal, switching, AC 110 - 230V, 50/60Hz

Mechanical

Housing	Metal Enclosure
Color	Black
Dimensions (LxWxH)	482 x 420 x 44 mm (with rack ears), 1RU
Weight	8.5 kg

Environments

Operating Temperature	0°C ~ 40°C
Storage Temperature	-20°C ~ 70°C
Relative Humidity	10%~90% RH (non-condensing)

All trademarks are the property of their respective owners. Aberman assumes no responsibility for any errors that may appear in this publication. Product, pricing and feature information contained herein is subject to change without notice.

Aberman logo and its associated visual identity are trademarks or registered trademarks of Aberman-AV and/or subsidiaries.

© 2026 Aberman-AV Co Ltd.